

## High Efficiency 2-Phase Boost Converter Minimizes Input and Output Current Ripple – Design Note 371

Goran Perica

### Introduction

Many automotive and industrial applications require higher voltages than is available on the input power supply rail. A simple DC/DC boost converter suffices when the power levels are in the 10W to 50W range, but if higher power levels are required, the limitations of a straightforward boost converter become quickly apparent. Boost converters convert a low input voltage to a higher output voltage by processing the input current with a boost inductor, power switch, output diode and output capacitor. As the output power level increases, the currents in these components increase as well. Switching currents

also increase proportional to the output-to-input voltage conversion ratio, so if the input voltage is low, the switching currents can overwhelm a simple boost converter and generate unacceptable EMI.

For example, consider Figure 1, a 12V input to 24V, 10A output switching converter operating at 300kHz. The currents processed by the converter in Figure 1 are shown in the first row of Table 1. The relatively high current levels in the switcher are reflected in high input and output ripple currents, which results in increased EMI.

LT, LTC, LT and Burst Mode are registered trademarks of Linear Technology Corporation. All other trademarks are the property of their respective owners.

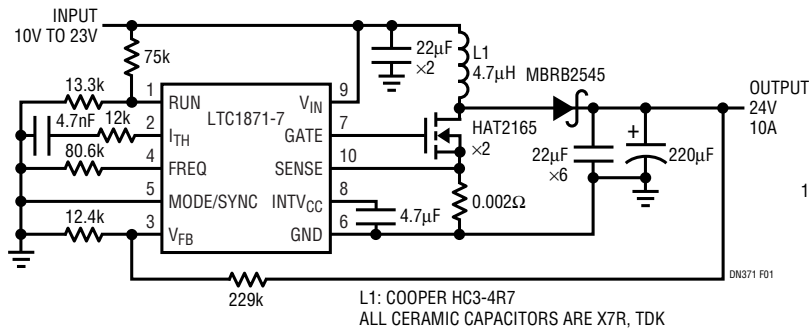

Figure 1a. Single-Phase Boost Converter: Can be Used to Convert 12V Input to 24V, 10A Output

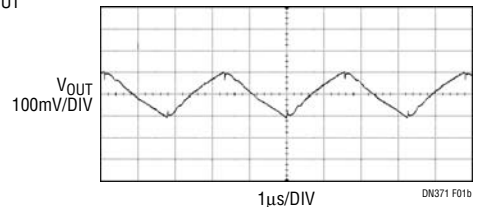

Figure 1b. Single-Phase Boost Converter Output Voltage Ripple

Table 1. Dual-Phase Boost Converter Has Lower Input and Output Ripple Currents and Voltages Than Single-Phase Boost Converter

	INPUT RMS CURRENT	INPUT RIPPLE CURRENT	MOSFET RMS DRAIN CURRENT	OUTPUT DIODE RMS CURRENT	OUTPUT CAPACITOR RMS CURRENT	OUTPUT CAPACITOR FREQUENCY	OUTPUT VOLTAGE RIPPLE
<b>SINGLE-PHASE BOOST CONVERTER</b>	21.1A	4.2Ap-p	15.4A	14.4A	10.5A	300kHz	212mV
<b>DUAL-PHASE BOOST CONVERTER</b>	20.7A	<b>0.17Ap-p</b>	2 × 7.4A	2 × 7.2A	<b>1.9A</b>	600kHz	<b>65mV</b>

The circuit shown in Figure 2 performs the same DC/DC conversion, but with greatly reduced input and output ripple, significantly reducing EMI, and at a higher effective switching frequency, which allows the use of two 22 $\mu$ F output capacitors versus six 22 $\mu$ F output capacitors required in Figure 1.

The trick is the 2-phase boost topology, which interleaves two 180° out-of-phase output channels to mutually cancel out input and output ripple current—the results are shown in the second row of Table 1. Each phase operates at 50% duty cycle and the rectified output currents from each phase flow directly to the load—namely the low inductor ripple current—so only a small amount of output current (shown in Table 1) is handled by the output capacitors.

The centerpiece of the design in Figure 2 is the LT<sup>®</sup>3782 2-phase current mode PWM controller. Current mode operation ensures balanced current sharing between the two power converters resulting in even power dissipation between the power stages.

The efficiency of the dual-phase converter, shown in Figure 3, is high enough that it can be built entirely with surface mount components—no need for heat sinks. In a

240W boost supply application, the power dissipation of 12.9W is relatively easy to manage in a well laid out, large multilayer PCB with some forced airflow.

### Conclusion

The simple LT3782 dual-phase switching boost converter improves on single-phase alternatives by allowing high power output with lower ripple currents, reduced heat dissipation and a more compact design.

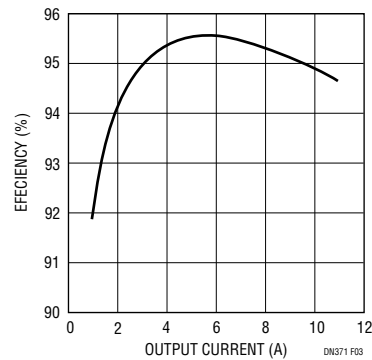

**Figure 3. 12V Input to 24V Output Dual-Phase Boost Converter Efficiency**

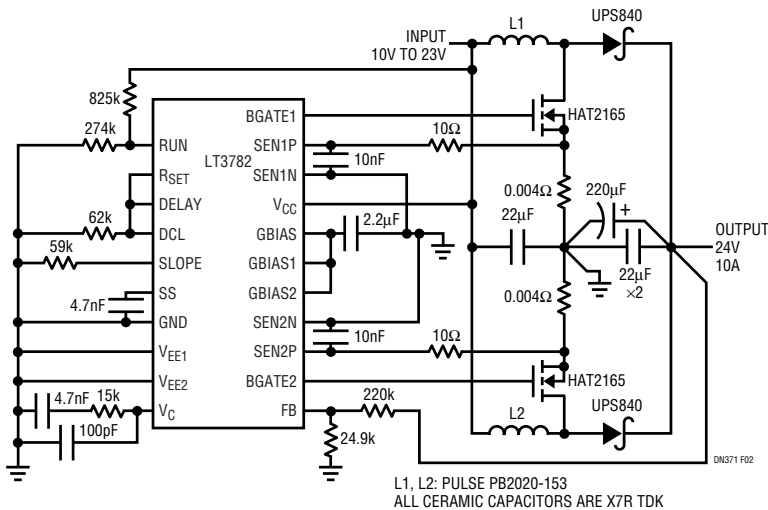

**Figure 2a. Dual-Phase Boost Converter Reduces EMI and Ripple Currents with a Minimum Input and Output Filtering**

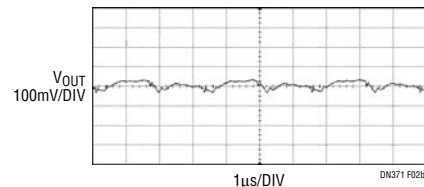

**Figure 2b. Dual-Phase Boost Converter Output Voltage Ripple**

**Data Sheet Download**

<http://www.linear.com>

For applications help,  
call (408) 432-1900, Ext. 2593